

BYM01-18-01MD

Solenoid for threaded cartridge valve

DC 12V
DC 24V

Other can be customized

- Applicable to 4-way solenoid hydraulic pressure reducing valve
- Equipped with manual adjustment device
- Dustproof and waterproof design
- Coil inner hole $\phi 18$. All-plastic sealing process

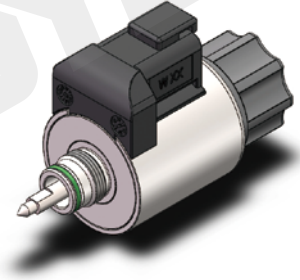

Outline and connection dimensions

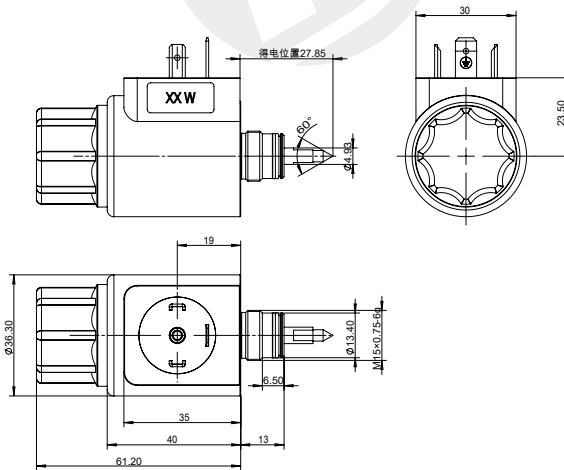

technical parameter

technical parameter		
Ambient temperature	°C	-25~50
Voltage fluctuation range	%	85 ~ 110
Rated power	W	16
Rated stroke	mm	1.5
Full stroke	mm	≥ 3
Working oil pressure	Mpa	≤ 21
Degree of protection		IP67
Operating frequency	T/h	12000
Power on duration	%	100
Insulation class		H(180)
Electrical connection mode		DT04-2P

103

BYM

F-S characteristic curve

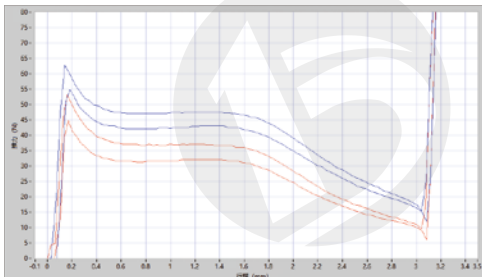

matters needing attention

1. The coil shall not be powered on alone, which has the risk of burning!
2. Non explosion-proof coil shall not be used in medium with explosion risk!
3. After the coil is installed, it must be grounded reliably, otherwise there is a risk of electric shock !