

BYG05-45-01MG

比例阀用电磁铁

Electromagnet for proportional valve

DC12V 2.36A
DC24V 1.18A

其它规格可定做
Other can be customized

- 适用于 6 通径液压比例电磁阀
- 螺纹连接，线圈可实现免停机更换
- 配备手动应急装置
- 配备手动调整装置（内置弹簧）
- 线圈内孔 $\phi 23$ ，全塑封工艺
- Applicable to 6-way hydraulic proportional solenoid valve
- Threaded connection, coil can be replaced without stopping
- Equipped with manual emergency device
- Equipped with manual adjustment device (built-in spring)
- Coil inner hole $\phi 23$. All-plastic sealing process



外形及连接尺寸

Outline and connection dimensions

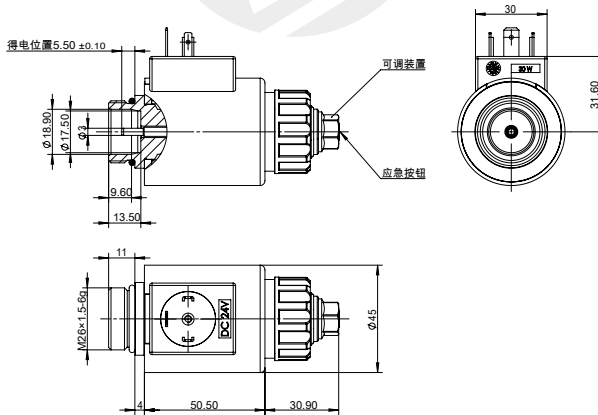

技术参数 / technical parameter

环境温度 Ambient temperature	°C	-25~50	
额定电压 Rated voltage	VDC	12	24
额定电流 Rated current	A	2.36	1.18
最大电流 Maximum current	A	2.4	1.2
额定电阻 Rated resistance	Ω	2.5	10
额定行程 Rated stroke	mm	3.2	
全行程 Full stroke	mm	6.5	
额定推力 Rated thrust	N	50	
力滞环 Force hysteresis	%	≤ 4	
电流滞环 Current hysteresis	%	≤ 4	
重复精度 Repetition accuracy	%	≤ 1	
工作油压 Working oil pressure	MPa	≤ 21	
防护等级 Degree of protection		IP65	
通电持续率 Power on duration	%	100	
绝缘等级 Insulation class		H (180)	
电气连接方式 Electrical connection mode		DIN43650	

力 - 位移特性曲线

F-S characteristic curve

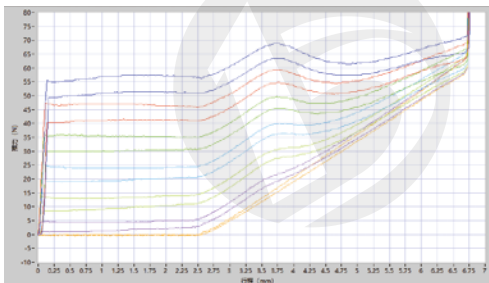

注意事项

matters needing attention

1. 首次使用或长期停机后启用，请先将系统内空气排净！
2. 可任意方向安装，建议水平安装。
1. After the first use or long-term shutdown, please exhaust the air in the system first!
2. It can be installed in any direction, and it is recommended to install horizontally.

样本数据来源于试验室环境，仅供参考，贵公司如需最新数据或有特殊需求，欢迎联系博业液压工程师。
The sample data comes from the laboratory environment and is only for reference. If your company needs the latest data or has special needs, please contact Boye hydraulic engineer.